

Protective covers - EV-T2SOC-B - 1164293

Please be informed that the data shown in this PDF Document is generated from our Online Catalog. Please find the complete data in the user's documentation. Our General Terms of Use for Downloads are valid (<http://phoenixcontact.com/download>)



CHARX connect, Protective covers, self-closing, rear protective cover screw connection, for attaching to infrastructure charging sockets, Type 2, Front mounting, screwed on the back, M5 thread, Basic, Embossed PHOENIX CONTACT logo

Product Description

Self-closing protective cover for infrastructure socket outlet

Your advantages

- ✓ Developed and produced in accordance with the IATF 16949 automotive standard and ISO 9001
- ✓ Individual branding, thanks to the use your own logo
- ✓ Reliable protection of your socket outlet from weather and vandalism



Key Commercial Data

Packing unit	1 pc
GTIN	 4 063151 177324
GTIN	4063151177324
Custom tariff number	39269097
Country of origin	Poland

Technical data

Product definition

Type	self-closing
	rear protective cover screw connection
Application	for attaching to infrastructure charging sockets
Affixed logo	Embossed PHOENIX CONTACT logo
Design	Basic

Protective covers - EV-T2SOC-B - 1164293

Technical data

Product definition

Charging standard	Type 2
Charging mode	Mode 3, Case B

Dimensions

Height	93.7 mm
Width	85 mm
Depth	32.5 mm
Bore dimensions	60 mm x 60 mm

Ambient conditions

Max. altitude	5000 m (above sea level)
---------------	--------------------------

Mounting

Possible mounting positions	Front mounting, screwed on the back
Required mounting screws	M5 thread

Design

Design line	Basic
-------------	-------

Environmental Product Compliance

China RoHS	Environmentally friendly use period: unlimited = EFUP-e
	No hazardous substances above threshold values

Drawings

Dimensional drawing

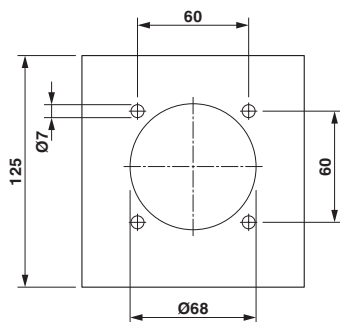

Hole image

Dimensional drawing

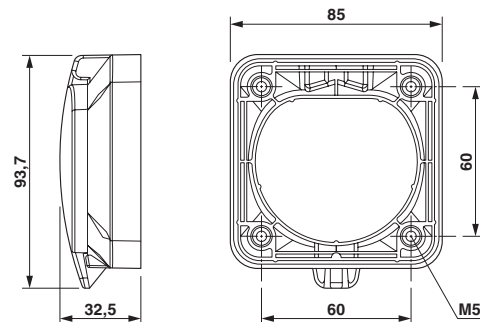

Dimensional drawing

Protective covers - EV-T2SOC-B - 1164293

Schematic diagram

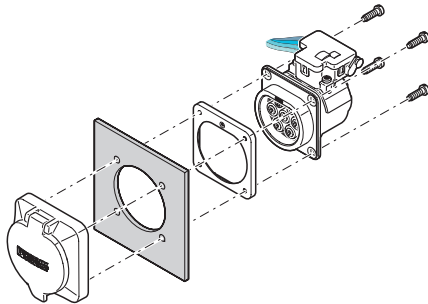

Rear mounting with rear protective cover screw connection
The screw connection for a protective cover from the accessories range (EV-T2SC) only supports rear mounting. The panel thickness must not exceed 5 mm. The sealing frame that is slid on from the rear must contact the housing panel flush with the flat side and must completely surround the infrastructure socket outlet.

Schematic diagram

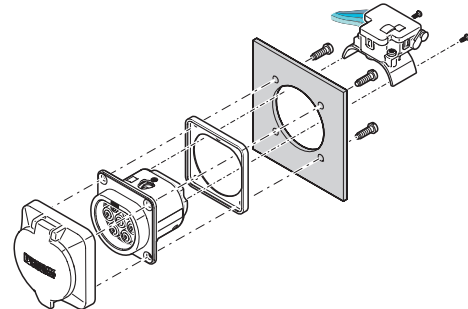

Front mounting with rear protective cover screw connection
Front mounting is only possible when the locking actuator is removed. We recommend using an infrastructure socket outlet without pre-assembled locking actuator (EV-T2M3SE-...E0..., e.g., 1621729).
The screw connection for a protective cover from the accessories range (EV-T2SC) only supports rear mounting. The panel thickness must not exceed 10 mm. The sealing frame that is slid on from the front must contact the housing panel flush with the flat side and must completely surround the infrastructure socket outlet.

Classifications

eCl@ss

eCl@ss 10.0.1	27144792
eCl@ss 11.0	27144792
eCl@ss 9.0	27144792

ETIM

ETIM 7.0	EC002884
----------	----------

Accessories

Accessories

Infrastructure socket outlet

Socket Outlet - EV-T2M3SO12-3P-B - 1164309



CHARX connect, Socket Outlet, rear protective cover screw connection, can be reconnected, For charging electric vehicles (EV) with alternating current (AC), Compatible with infrastructure charging plugs, Type 2, IEC 62196-2, 32 A / 480 V (AC), without cable, Locking actuator: 12 V, 3-position, Rear panel mounting, M5 thread, Basic, "PHOENIX CONTACT" logo

Protective covers - EV-T2SOC-B - 1164293

Accessories

Socket Outlet - EV-T2M3SO12-4P-B - 1164300



CHARX connect, Socket Outlet, rear protective cover screw connection, can be reconnected, For charging electric vehicles (EV) with alternating current (AC), Compatible with infrastructure charging plugs, Type 2, IEC 62196-2, 32 A / 480 V (AC), without cable, Locking actuator: 12 V, 4-position, Rear panel mounting, Basic, "PHOENIX CONTACT" logo